

HS-420 Accelerometer

4-20mA velocity output via Braided Cable

Key Features

- For use with PLC/DCS systems
- Customisable features

Industries

Building services, Pulp and Paper, Mining, Metals, Utilities, Automotive, Water, Pharmaceutical

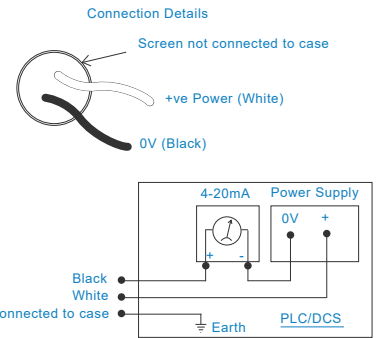
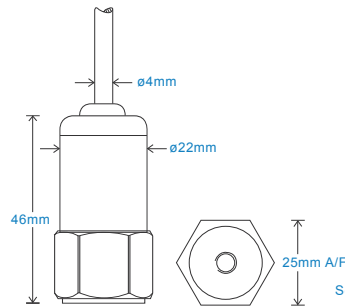

Technical Performance

Mounted Base Resonance	5kHz min
Velocity Ranges	see: 'How To Order' table $\pm 10\%$ Nominal 80Hz at 22°C
Frequency Response	10Hz (600cpm) to 1kHz (60kcpm) $\pm 5\%$ - ISO10816
Isolation	Base isolated
Range	50g peak
Transverse Sensitivity	Less than 5%

Mechanical

Case Material	Stainless Steel
Sensing Element/Construction	PZT/Compression
Mounting Torque	8Nm
Weight	100gms (nominal) body only
Maximum Cable Length	1000 metres
Standard Cable Length	5 metres
Screened Cable	Braided - length to be specified with order
Mounting Threads	see: 'How To Order' table

Electrical

Current Output	4-20mA DC proportional to Velocity Range
Supply Voltage	15-30 Volts DC (for 4-20mA)
Settling Time	2 seconds
Output Impedance	Loop Resistance 600 Ohms max. at 24 Volts
Case Isolation	$>10^8$ Ohms at 500 Volts

Environmental

Operating Temperature Range	-25 to 120°C
Sealing	IP65
Maximum Shock	5000g
EMC	EN61326-1:2013

Typical Frequency Response

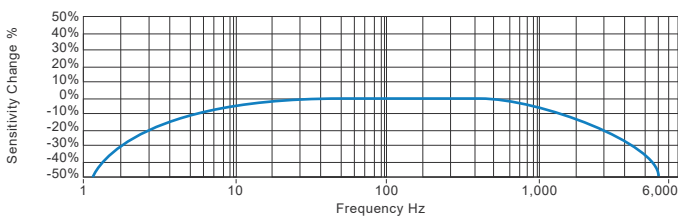

Applications

Fans, Motors, Pumps, Compressors, Centrifuges, Conveyors, Air Handlers, Gearboxes, Rolls, Dryers, Presses, Cooling, VAC, Spindles, Machine Tooling, Process Equipment

Vibration sensor should be firmly fixed to a flat surface (spot face surface may be needed to be produced and cable anchored to sensor body.)

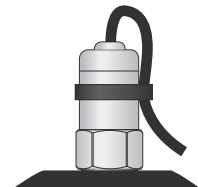

How To Order

Product Prefix HS - Hansford Sensors	Product Series 420 - Industrial Vibration Sensor	Cable Length (if integral cable) QXX - length specified in metres														
H	S	4	2	0	X	X	X	X	X	X	X	X	X	X		
Extra Options (if required) F - Filtered I - Intrinsically Safe L - 316L Stainless Steel RT - Temperature Output PT100 S - 90° Side Exit T - Temperature Output					P - Peak Range PP - Peak to Peak Range			Velocity Range (RMS unless specified) 010 - 0-10 mm/sec 020 - 0-20 mm/sec 025 - 0-25 mm/sec 050 - 0-50 mm/sec 100 - 0-100 mm/sec			Cable/Connector 01 - PUR 02 - Braided 07 - Silicon 08 - Flame Retardant 50 - 2 Pin MS 54 - M12			Mounting Threads 01 - 1/4-28" UNF Female 02 - 1/4-28" UNF Male 05 - Quick Fit Female 06 - M6 x 1mm Male 08 - M8 x 1.25mm Male 10 - M10 x 1.5mm Male		



www.hansfordsensors.com
sales@hansfordsensors.com

We reserve the right to alter the specification of this product without prior notice
TS009.12

